

Layflat Control

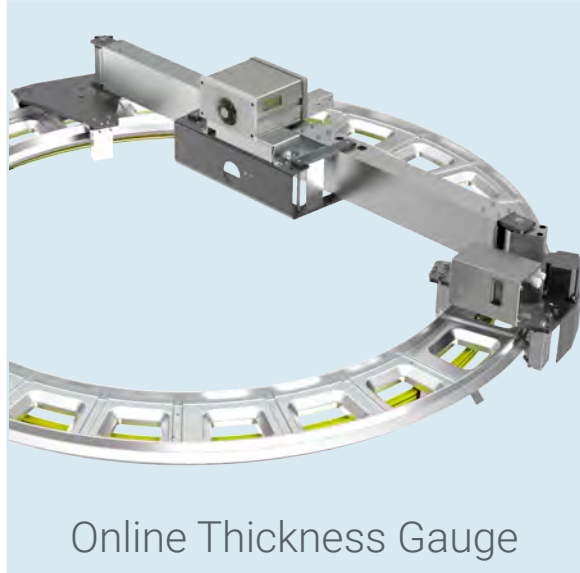

Online Thickness Gauge



Offline Thickness Gauge



Operating Software

Manage film extrusion quality with measuring and control upgrades

K-500 Rotomat KT

The K-500 thickness sensor is based on the capacitive measuring principle. The Rotomat KT ensures a quick profile refresh by its either oscillating or continuous rotation. It takes only 36 seconds on the standard sized scanners.

Application: The K-500 Rotomat KT can be used for a wide range of different films.

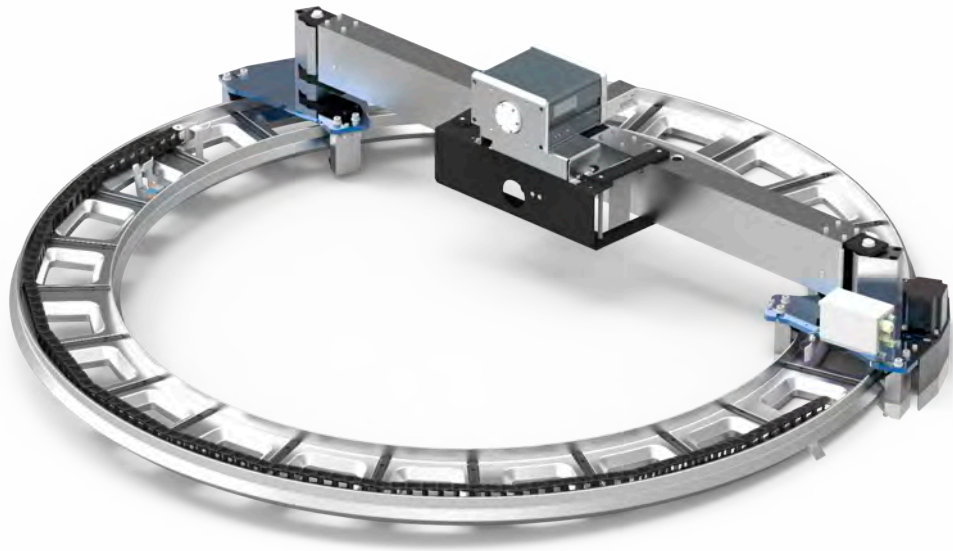

KCF-700 Rotomat KT

The KCF-700 is based on the capacitive measuring principle. By using an air gap between film and measuring head, a production of sensitive films without scratches is ensured. The Rotomat KT ensures a quick profile refresh.

Application: The KCF-700 Rotomat KT is the ideal solution to measure sticky or sensitive films. (e.g. EVA)

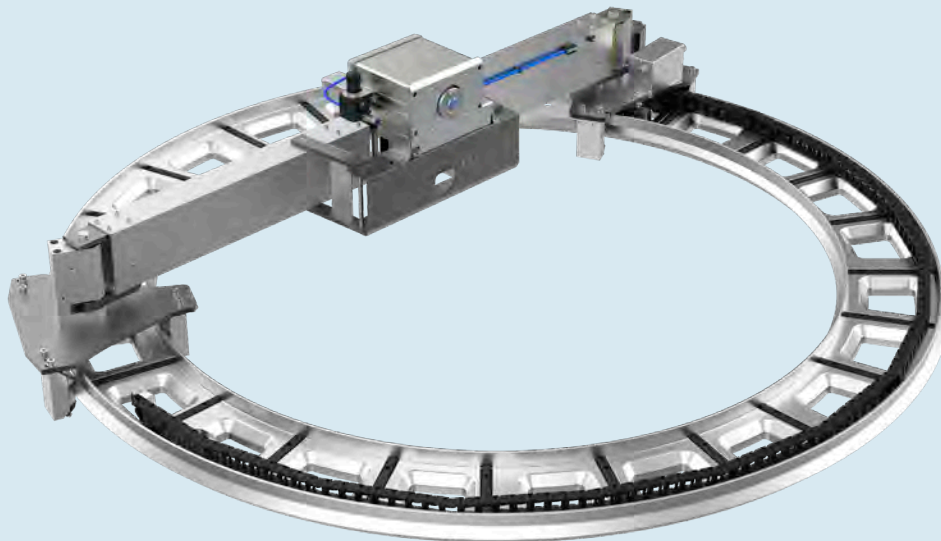

K-XRay Rotomat KT

This thickness gauge is based on X-Ray backscattering technology, allowing thickness measurement at high resolution even on very thin films.

Application: The K-XRAY Rotomat KT makes precise thickness measurements of sensitive barrier films on the bubble possible. It has significant advantages over today's radioactive sensors.

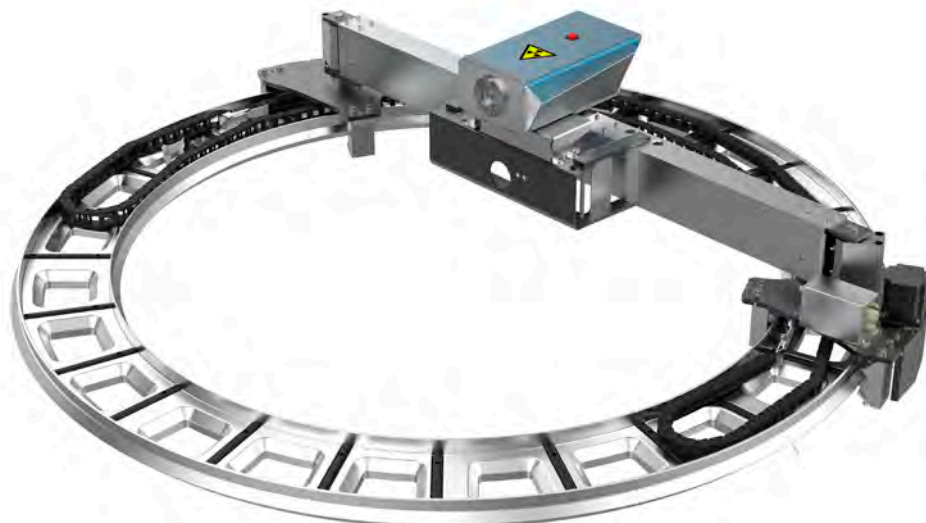

KNC-600 Linear Scanner

The KNC-600 is a capacitive, non-contact thickness sensor. Integrated into the linear scanner, it forms a very effective measuring device to measure the thickness profile on flat films. Unlike other systems it operates from just one side of the film.

Application: The KNC-600 Linear Scanner is used on MDO and Cast Film Lines.

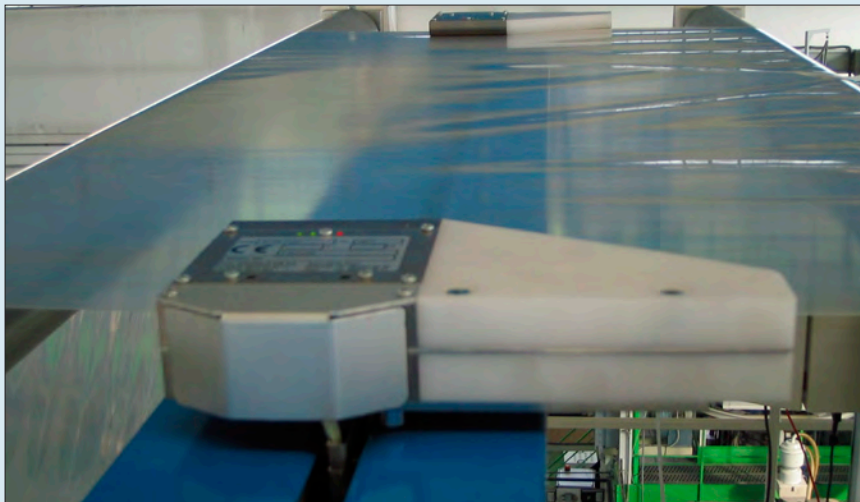
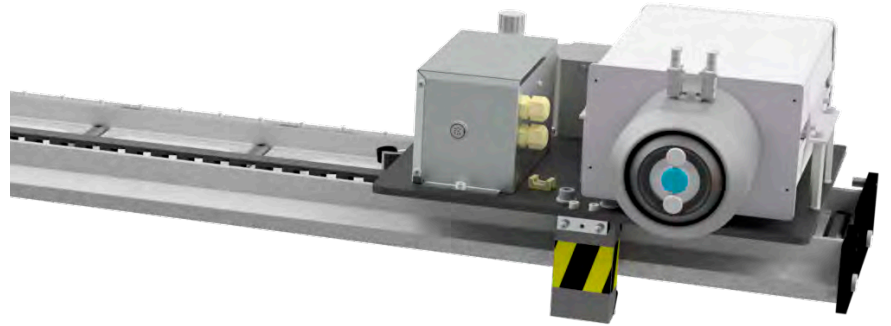

S-100 Twin

A capacitive measuring system for barrier films. Any film can be measured except electrical conductive materials. Also, layflat and web position is measured with the same unit. The profile update depends on the rotation speed of the collapsing frame.

Application: The S-100 Twin has been developed for non-contact measurement of barrier films.

K-300 CF Gauge with Profilstar.Net

The K-300 CF Gauge is a capacitive thickness sensor which is mounted on the collapsing frame. It uses the oscillation of the haul-off or die to measure the complete thickness profile.

The software Profilstar.Net shows the linear thickness profile, the circular profile as well as the trend. Using this information allows a quick centering of the die.

Application: The K-300 CF Gauge with the software Profilstar.Net is a very effective and economic retrofit package for existing blown film lines.

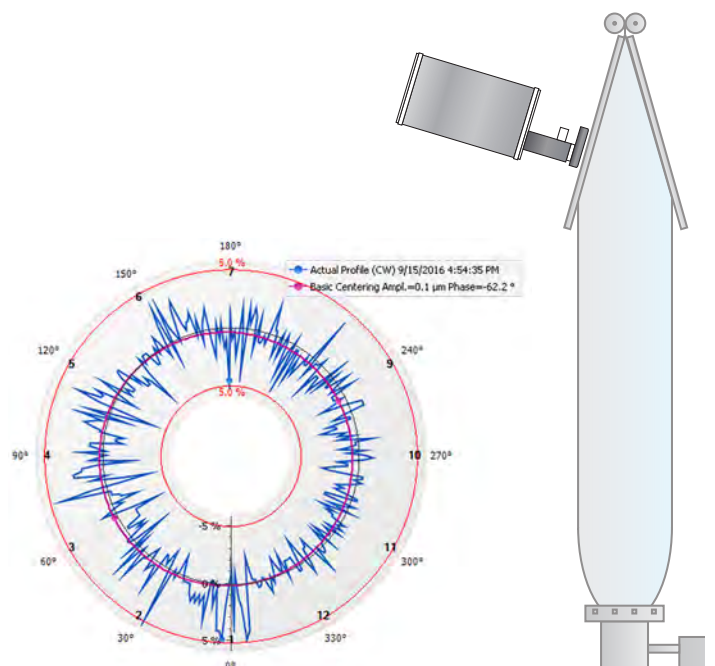

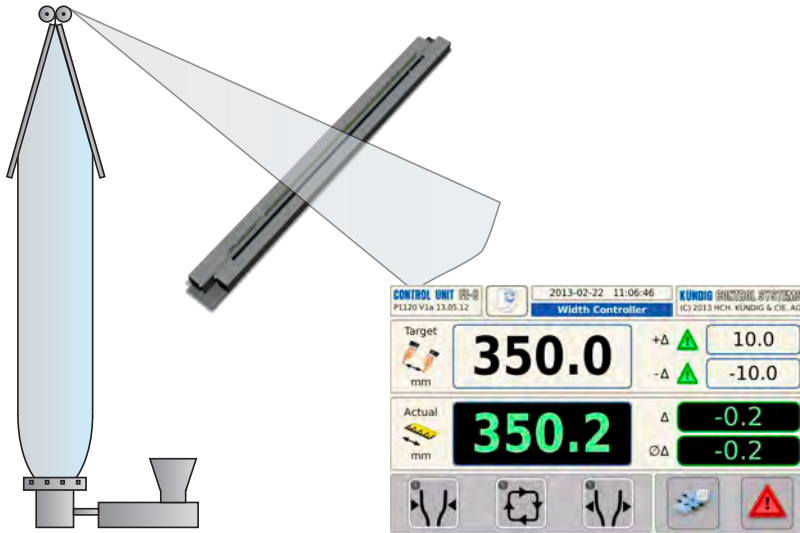

FE-8 Width Gauge

Two optical sensors measure the layflat of the film. The non-contact measuring bars are mechanically adjustable in length, so that it can easily fit in the tower of the line. The control unit regulates the width of lines with or without IBC systems.

Application: The automatic width control FE-8 is a self-sufficient system to retrofit existing lines, a small investment that assures you considerable savings of raw material and a very short payback period.

Filmtest 3G

The newly designed „Variospeed“ sample scanner uses optical sensors to track the film edges; automatically transporting the sample through the capacitive measuring device. This eliminates manual guiding by the operator. The square meter weight is determined using length, width and weight. Then the average thickness is calculated based on the density. This method allows a much more precise thickness profile measurement than other systems on the market.

Application: The Filmtest is used for process optimization and quality control labs.

Profile Genius: This software tool can especially assist in detecting reasons for thickness profile variations in the blown film extrusion process. Using this information enables the operator to focus in on the correct process areas to reduce the profile variation.

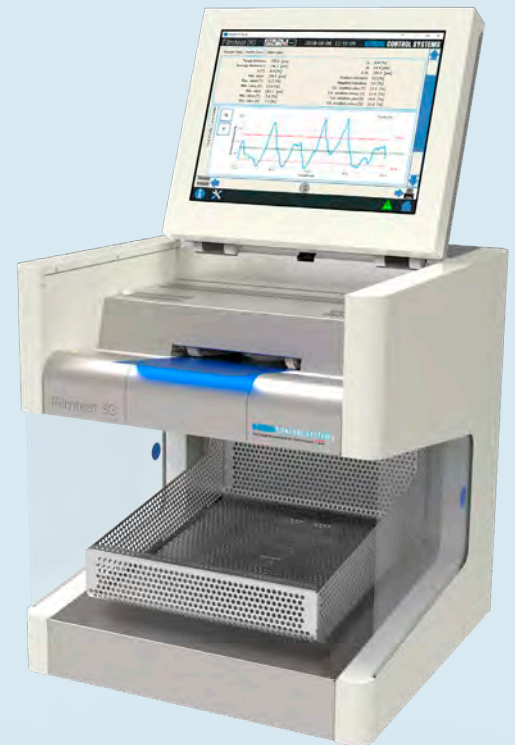

HCH. KÜNDIG & CIE. AG
 Joweid Zentrum 11 | P.O. Box 526
 CH-8630 Rüti ZH | Switzerland

+41 55 250 3616
 @ sales@gauge.ch
 www gauge.ch

KÜNDIG CONTROL SYSTEMS
 The Gauge Manufacturer for Film Extrusion  SWISS MADE